

Tailoring RF Performance by Optimization of Reflector Boundary for Spacecraft Antenna

Ramesh C. Gupta¹, Sravan K. Sagi², Milind B. Mahajan³

Abstract – A novel technique to get customized RF performance for Satellite Reflector antenna, has presented in this paper. The reflector boundary has optimized to get modified RF performance according to specified RF goal. The presented technique provides additional and augmented frontier apart from conventional methods, such as surface shaping, optics optimization and by optimizing feed pattern, to achieve tailored RF performance of a Satellite Reflector Antenna. The irregular rim optimization along with surface shaping will be very useful for future antenna designing. The measured results of 1.2m C-Tx/Tx Offset Reflector Antenna is agreeing well with predicted results from method of moments (MoM) method.

Keywords – Antenna optimization, Feed-Horn, Irregular boundary reflector antenna, Offset reflector Antenna, Satellite Antenna.

I. INTRODUCTION

With advent of rising satellite market, antenna with tailored RF performance is demanded for the satellite. Advancement in fabrication technology, analysis methods, antenna optimization technique, vendors' demand and designer experience etc. are driving force to design improved antenna with pace of time.

For communication spacecraft antenna, important parameters are Edge of Coverage (EoC) Gain, Cross-polarization discrimination (XPD) within coverage, Smaller Gain slope to have lower pointing error due to satellite platform in-stability.

Tailored RF performance could achieved using reflector surface shaping [1]. Here reflector surface is undulated using Zernike or spline adjustable surface according to defined station Gain and/or Cross-polar goal. Contoured beam, flat-top pattern, high-efficiency spot beam etc. can be obtained using surface shaping. Optimization of feed radiation pattern [2] also affect secondary radiation pattern of the reflector antenna. Edge taper, cross-polar level and phase pattern of the feed horn should optimize to get desired reflector performance. Optimization of the antenna optics [2] also improve reflector RF performance. Change in Reflector Rim considered by several researchers to get desired RF performance [3]-[8].

Article history: Received December 23, 2023; Accepted May 08, 2024.

¹Ramesh Chandra is with Advanced Antenna Technology Division (AATD), Space Applications Centre (SAC), Indian Space Research Organisation (ISRO), Ahmedabad, India, E-mail: rameshgupta@sac.isro.gov.in

²Sravan Kumar Sagi is with Satellite & Navigation Antenna Group (SNAG), SAC (ISRO), E-mail: sravan@sac.isro.gov.in,

³Milind B. Mahajan is with Antenna Systems Area (ASA), SAC (ISRO), E-mail: mb_mahajan@sac.isro.gov.in

A surface shaping based Reflector Antenna has devised by Werner [1] for Contoured Beam. Gupta et al [2] has shown systematically trimming the reflector rim improve cross-pol isolation for offset reflector antenna. Savarese and group [3] have shown that Reflector Antenna performance, can controlled by edge loading. Reduction of radiation has achieved in the shadow region by structurally changing the rim of reflector antennas [4]. I. J. Gupta and colleagues [5] has investigated for Blended Rolled Edges for Compact Range Reflectors. Paunonen [6] has considered Reflector antenna with cutting Rim for Switched-Beam Antenna. Jiang et al. [7] carried out research on Serrations of Reflector for compact antenna test range. Ellingson and Sengupta [8] had modified side-lobe for Reflector Antennas by reconfigurable Rim Scattering. The Origami Reflector Antenna has studied by Wilson [9]. Here, a parabolic reflector has discretized into an origami arrangement. It uses natural pivots with origami structures to change shape of the reflector through shape memory alloy (SMA) actuators, which cause desired directionality of signal. A stepped reflector architecture has designed and developed by V. Manohar and Yahya Rahmat-Samii [10]. It consists of a discrete number of parabolic sections that scatter in phase to produce high efficiencies (50% for 12% bandwidth), making it an attractive option for compact high gain antennas. Rao et al. [11] developed a petal-based segmented reflector antenna for four bands. The main reflector has made by six identical petals which can be rapidly assembled and disassembled.

In our research work, reflector antenna boundary (rim) has optimized to improve its RF performance. Reflector boundary for the antenna has parameterized. Here spline interpolation have used between rim points, so that smooth and continuous rim could achieved after optimization. Finally, parameterized rim has optimized according to specified RF goal. This technique is simple. A lightweight, low cost and high performance antenna can designed using this technique. If, this irregular rim optimization technique would use with surface shaping, optics optimization, feed optimization in presence of reflector, very high performance antenna can designed for spacecraft.

In the next section, a new technique and optimization of Reflector Boundary for Spacecraft Antenna to provide better RF performance, has presented. correlation of the predicted results with measured results for conventional offset reflector antenna is conversed in section III. Outcomes for Irregular boundary reflector antenna are deliberated in section IV. In section V, conclusion and prospect research scope for Irregular boundary reflector antenna is stated.

II. DESIGN AND ANALYSIS OF OFFSET REFLECTOR AND HORN ANTENNA

For 1K Ton category smaller satellite bus, Separate Tx and Rx antennas at C-Band has configured for the FSS (Fixed Satellite Services) payload (Figure-1).

For illuminating Offset Reflector antenna, horn with axial corrugations has designed & analyzed using Champ3D [13]. At initial level of optimization, corrugation depth, have chosen $\lambda/4$, where λ is wavelength. Ridge thickness of the horn has kept 1 mm fixed for all corrugations, for ease of fabrication. Axial distance and slot width of each corrugation have selected $\lambda/4$, as an initial value. Horn input radius has selected to propagate only TE₁₁ mode. Aperture radius of the horn has chosen to get desired peak gain or edge taper of the horn. Horn return loss, edge taper at subtended angle and cross-polar level, have optimized for entire bandwidth, by adjusting axial depth, width and axial distance of each corrugation. 3D view of the horn geometry and direct compatible ortho-mode transducer (OMT) has shown in Figure 2. For detailed design of OMT, our published paper can be referred [12]. Return loss of the horn and OMT assembly has achieved better than 17 dB at both direct and coupled ports.

The specification for C-Tx/Tx reflector antenna, are given in Table-I. The antenna has designed for transmit operation on C-band for Linear Horizontal and vertical polarization, simultaneously. The antenna has mounted on lateral side of west panel of spacecraft. It is stowed during launch and deployed at space with hinge & deployment mechanism. Half-height WR-187 waveguide has selected to handle high power and to save mass. Spot beam has planned for Indian coverage to provide specified Gain and XPD. EoC Gain has derived from link budget of the payload.

TABLE 1
SPECIFICATION OF C-TX OFFSET REFLECTOR ANTENNA

Parameter	Value
Frequency Band	4.53-4.73 GHz
Polarization	Dual Linear Polarization
EoC Gain	> 26.5 dBi
EoC XPD	> 26 dB
Coverage	India
Return loss	> 17 dB
Interface	Half-height WR-187
Mounting	West-side of spacecraft

Optics of the Offset reflector antenna has given in Table 2. To avoid scattering of rays from spacecraft panel, adequate offset has given in reflector antenna. The offset for reflector antenna has kept $D/10$, where D is diameter of reflector antenna. By scattering analysis, it has found for this value of offset, spacecraft body has negligible impact on RF performance. F/D has chosen 1.13 to get good cross-polar isolation and accommodation of feed at EV (Earth viewing) deck of spacecraft. Feed edge taper has selected -12 dB at subtended angle at reflector edge to get optimum efficiency. Feed tilt angle and subtended angle are computed using formula given in [14].

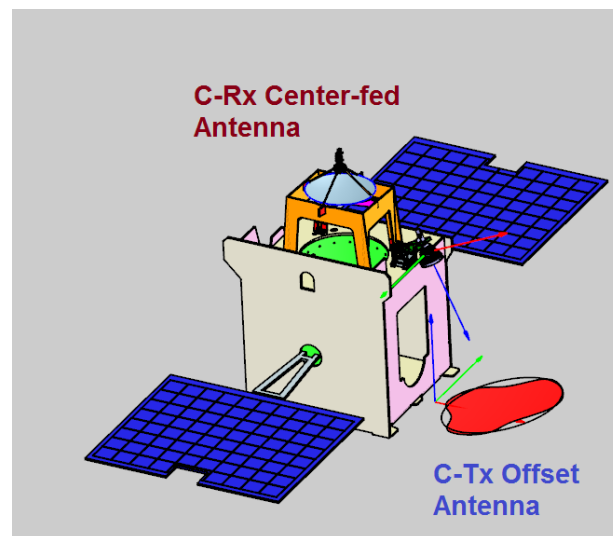

Fig. 1. Separate Tx and Rx antennas at C-band with spacecraft bus

TABLE 2
OPTICS OF OFFSET REFLECTOR ANTENNA

Parameter	Value
Reflector Size	1.5m
Focal length	1.7m
Offset Clearance	150 mm
Feed tilt Angle	24.88°
Edge taper at subtended angle	-12 dB @ 19.13°
Phase center for Feed	-108.5 mm from feed aperture

The antenna is operating at satellite location 83°E and has beam center at 82°E 22°N on Earth. The coupled and direct ports of feed has configured for Lin-H and Lin-V respectively.

Our principal aim is to design and investigate Irregular optimized boundary of reflector Antenna for tailored and better RF performance. Hence, we have not focused on option of Feed system, reflector configuration, reflector optics and surface shaping etc. in present work.

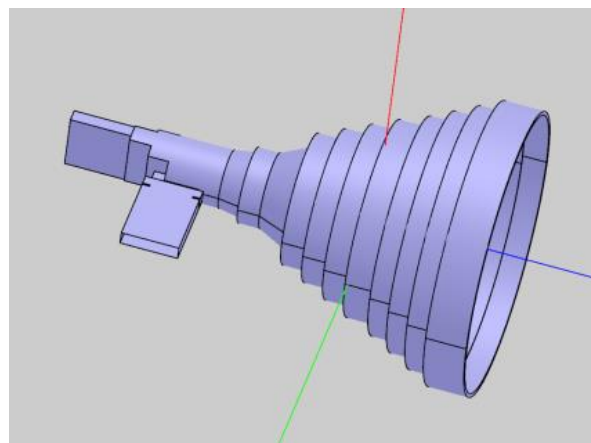

Fig. 2. Axial Corrugated Horn with compact and direct compatible OMT

III. OPTIMIZATION PROCEDURE FOR IRREGULAR BOUNDARY OFFSET REFLECTOR ANTENNA

Using Irregular boundary reflector Technique, XPD performance has improved with small change in Coverage Gain.

Succeeding techniques have exploited and utilized for irregular boundary of reflector antenna optimization to achieve desired RF performance: -

(i) Initially, Offset reflector antenna has designed to have clearance from spacecraft scattering. The design is also finalized from interface and accommodation point of view. With help of MATLAB [15] code, rim of the reflector is computed and parameterized.

(ii) With help of MATLAB code, desired RF goal for Antenna Gain and XPD at several stations within Indian Coverage polygon are generated and used in optimization. In present case, we have given higher weight on XPD improvement.

(iii) Variable of the parameterized boundary of the Offset reflector antenna is optimized for RF Goal in Tiera Tool [14]. For optimization, Physical Optics/Physical Theory of Diffraction (PO/PTD) method, has been used for faster solution. Spline interpolation between boundary points has been applied during optimization to get smoother and continuous reflector boundary. ‘Minimax’ and ‘Multi-level coordinate search (MCS)’ optimization algorithm, have been used on alternate & sequential basis, for the optimization.

(iv) Finally, The Optimized Reflector Antenna with horn and OMT, has been analyzed, as one entity, using method of moments (MoM) method.

(v) In this manner, we have achieved better secondary results with optimized irregular boundary reflector antenna (Figure 3).

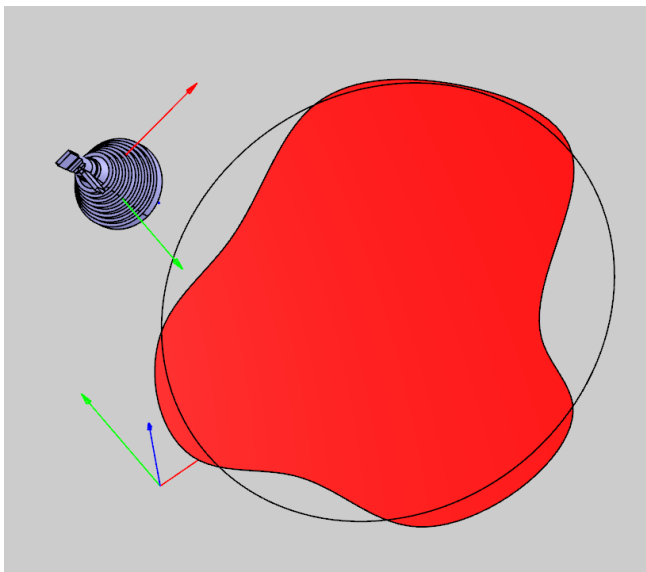

Fig. 3. Optimized irregular boundary reflector antenna; circular boundary in black color is initial boundary

IV. VALIDATION OF THE APPLIED ANALYSIS

The Conventional Offset reflector antenna has analyzed using Method of Moments (MoM) using Tiera Tool [14]. We have considered horn, OMT and reflector in the analysis. The reflector has been fabricated with help of CFRP using mold technique. The realized antenna is characterized for Gain and Pattern Measurement (Fig. 4) at SAC Compact Antenna Test Range (CATR). Feed has aligned with respect to antenna coordinate system. Offset reflector antenna has mounted on CATR position and aligned with NPA (nominal lane wave axis) of CATR. Pattern raster (with Az and EL angle) has measured. Gain of the antenna has measured with standard gain antenna using gain comparison method. Good agreement between predicted and measured EoC Gain and XPD results have seen and given in Fig. 5. It validates the analysis procedure. This validation ensures the RF results presented for Irregular-boundary reflector antenna would be accurate and can be achieved after fabrication and test of the antenna.

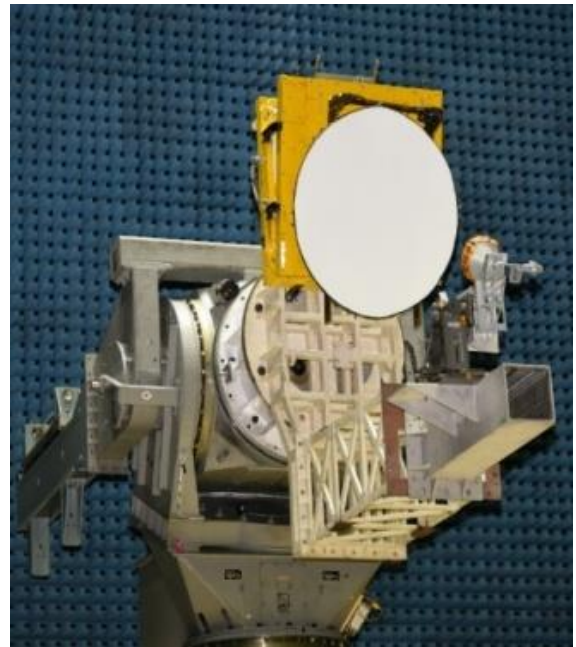
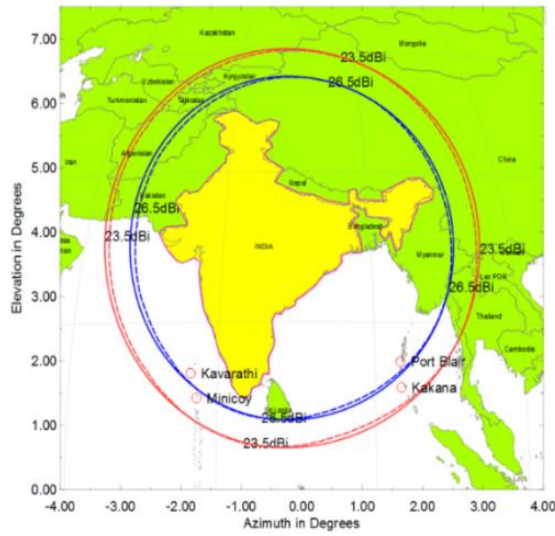

Fig. 4. Photograph of fabricated Conventional offset reflector antenna

Predicted and measured Peak Gain, have good correlation for Conventional Offset reflector antenna for both polarization and over the band and listed in Table 3.

TABLE 3
PEAK GAIN FOR CONVENTIONAL ANTENNA

Frequency	Polarization	Peak Gain (Predicted)	Peak Gain (Measured)
4.53GHz	Lin-V	33.60 dBi	33.52 dBi
	Lin-H	33.53 dBi	33.57 dBi
4.73 GHz	Lin-V	33.79 dBi	34.05 dBi
	Lin-H	33.81 dBi	33.91 dBi



(a)

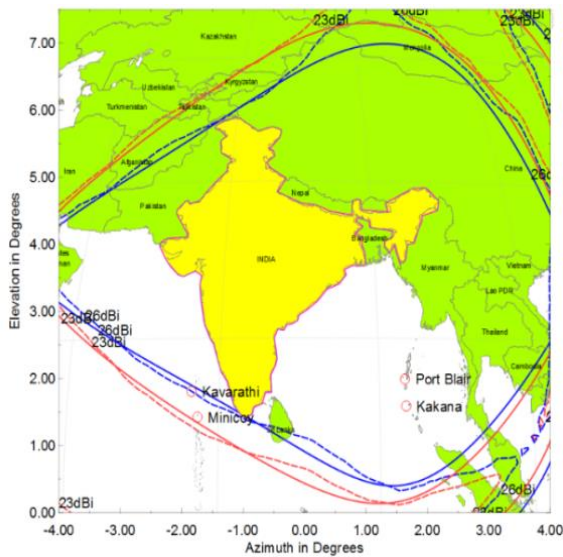

(b)

Fig 5. Overlaid contours for predicted (solid line) and measured (dotted line) results for Conventional Offset reflector antenna at 4.53 GHz Lin-V: (a) EoC Gain, (b) XPD

V. RESULTS AND DISCUSSION

The predicted performance of the reflector, are presented at this juncture. The EoC Gain contour for Irregular-boundary and conventional reflector antenna has been displayed in Figure 6. EoC Gain contour for Irregular-boundary reflector antenna, is slightly changed in comparison of convention reflector antenna.

The XPD contour for Irregular-boundary and conventional reflector antenna has been depicted in Figure 7. XPD contour for Irregular-boundary reflector antenna, is improved within coverage, in comparison of convention reflector antenna.

EoC Gain for Irregular-boundary and circular boundary reflector Antenna are listed in Table 4. EoC Gain for Irregular-boundary is degraded slightly.

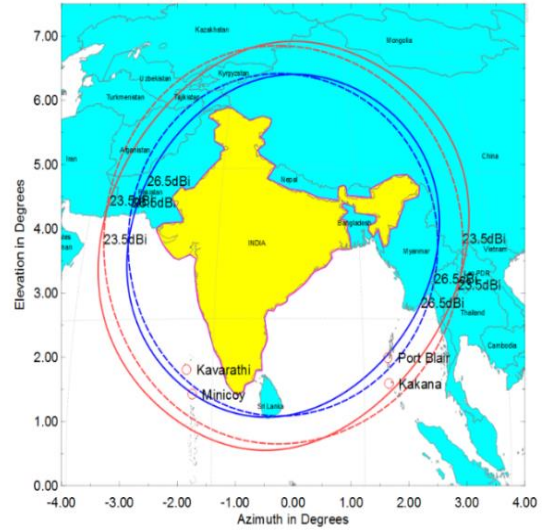

(a)

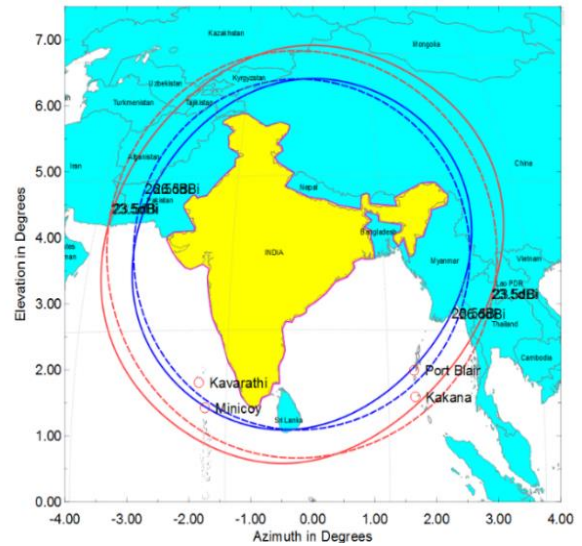

(b)

Fig. 6 EoC Gain contour for Irregular-boundary reflector antenna (solid line) and conventional reflector antenna (dotted line) for: (a) 4.53 GHz Lin-V, (b) 4.53 GHz Lin-H

TABLE 4
EOC GAIN FOR CONVENTIONAL AND IRREGULAR BOUNDARY ANTENNA

Frequency	Polarization	EoC Gain for Circular-boundary reflector Antenna	EoC Gain for Irregular-boundary reflector Antenna
4.53GHz	Lin-V	27.4 dBi	27.3 dBi
	Lin-H	27.4 dBi	27.2 dBi
4.73 GHz	Lin-V	27.1 dBi	27.0 dBi
	Lin-H	27.0 dBi	27.0 dBi

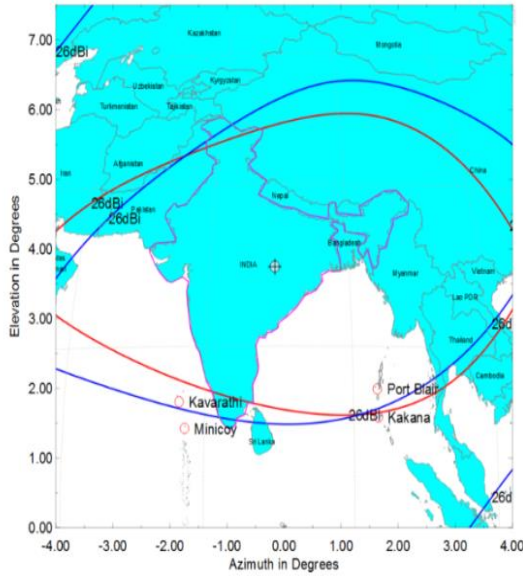

(a)

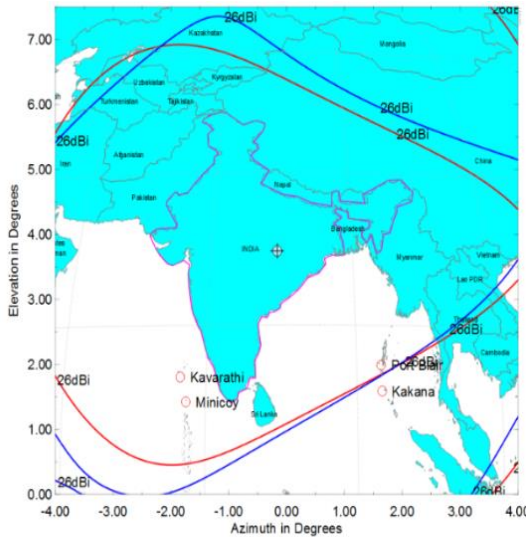

(b)

Fig. 7 XPD contour for Irregular-boundary reflector antenna (blue solid line) and conventional reflector antenna (red solid line) for: (a) 4.53 GHz Lin-V, (b) 4.53 GHz Lin-H

XPD for Irregular-boundary and circular boundary reflector Antenna are enumerated in Table 5. XPD for Irregular-boundary is improved comparatively.

TABLE 5

XPD FOR CONVENTIONAL AND IRREGULAR BOUNDARY ANTENNA

Frequency	Polarization	% Area for 30 dB XPD for Circular-boundary reflector Antenna	% Area for 30 dB XPD for Irregular-boundary reflector Antenna
4.53GHz	Lin-V	89.3%	90%
	Lin-H	89.6%	92%
4.73 GHz	Lin-V	83.1%	86%
	Lin-H	97.8%	100%

Table 6 compares Gain Slope for Irregular-boundary and circular boundary reflector Antenna. Gain slope for Irregular-boundary is improved comparatively. Hence, Irregular-boundary is lesser sensitive to satellite platform in-stability.

TABLE 6

GAIN SLOPE FOR CONVENTIONAL AND IRREGULAR BOUNDARY ANTENNA

Frequency	Polarization	Maximum Gain Slope for Circular-boundary reflector Antenna	Maximum Gain Slope for Irregular-boundary reflector Antenna
4.53GHz	Lin-V	5.2 dB/degree	5.1 dB/degree
	Lin-H	5.3 dB/degree	5.2 dB/degree
4.73 GHz	Lin-V	5.9 dB/degree	5.7 dB/degree
	Lin-H	5.9 dB/degree	5.6 dB/degree

VI. CONCLUSION

The optimization of reflector boundary with specified RF goal, provide improved RF performance in comparison of conventional reflector antenna. If reflector surface shaping and reflector boundary optimization are carried out together desired RF performance could be achieved. optimization of reflector boundary can be applied for any type of reflector configuration such as Gregorian antenna, Cassegrain antenna, ring focus antenna etc. This technique will provide additional flexibility and degree of freedom to design reflector antenna. In present case, improvement in XPD and Gain slope are small, but in case of bigger-sized antenna (diameter >2 meter) and for higher frequency band (Ku Band, Ka Band...), the improvement in XPD and Gain slope would be much higher.

ACKNOWLEDGEMENT

The writers want to thank Shri Nilesh M. Desai, Director, SAC (ISRO) and Shri K. S. Parikh, Associate Director, SAC (ISRO) for inspiration for scripting the research article. We acknowledge Dr. V. K. Singh and Dr. S. C. Bera for their serious scrutiny and practical submissions to augment value addition to our article. Authors thanks to SAC mechanical Engineers for fabrication and alignment and to ISITE CATF Team for measurement of the antenna.

REFERENCES

- [1] M. Balasubramanian, P. L. Werner and Douglas H. Werner, "A Curvature Based Shaped Reflector Antenna Design Method for Contoured Beam Synthesis," *IEEE Int Sym on Antenna & Propagation and USNC URSI Radio Science Meeting*, 2022, pp. 357-358.
- [2] R. C. Gupta, K. K. Sood and R. Jyoti, "Investigation of Factors Contributing Depolarization in offset reflector antenna and Trimmed-Reflector Offset Parabolic Antenna with Lower

- Cross-polarization,” in *International Journal of RF and Microwave Computer-Aided Engineering*, USA, vol. 22, no. 03, pp. 411-420, May 2012.
- [3] O. M. Bucci, G. D. Massa and C. Savarese, “Control of Reflector Antennas Performance by Rim Loading”, in *IEEE Transactions on Antennas & Propagation*, vol. 29, no. 5, pp. 773-779, Sept 1981.
- [4] G. L. James and V. Kerdeyielidis, “Selective Reduction in Back Radiation from Paraboloidal”, in *IEEE Transactions on Antennas & Propagation*, vol. 21, pp. 886-887, Nov 1973.
- [5] I. J. Gupta, K. P. Ericksen and W. D. Burnside, “A Method to Design Blended Rolled Edges for Compact Range Reflectors”, in *IEEE Transactions on Antennas & Propagation*, vol. 38, no. 6, pp. 853-861, June 1990.
- [6] J. Paunonen, “Reflectors Reflector Rim and Feed Considerations for Simple Switched-Beam Antenna Prototype”, in *IEEE Antennas & Propagation Magazine*, vol. 50, no. 6, pp. 108-114, Dec 2008.
- [7] Y. Jiang, C. Mo, W. Chen and D. Kong, “Research on Serrations of Reflector Used in CATR”, *Photonics & Electromagnetics Research Symposium, (PIERS-FALL)*, Xiamen, China, 17-20 December, 2019, pp. 1665-1669.
- [8] S. Ellingson and R. Sengupta, “Sidelobe Modification for Reflector Antennas by Electronically Reconfigurable Rim Scattering”, in *IEEE Antennas & Wireless Propagation Letters*, vol. 20, no. 6, pp. 1083-1186, June 2021 .
- [9] G. S. Wilson, *Shaping Radiation Contours with a Parabolic Active Reconfigurable Origami Reflector Antenna*, M.S. Thesis, Texas A&M University, August 2020.
- [10] V. Manohar and Y. Rahmat-Samii, “Stepped Parabolic Reflector Antennas: Simulation, Analysis, and Measurement,” in *IEEE Transactions on Antennas and Propagation*, vol. 69, no. 8, pp. 5078-5083, August 2021.
- [11] S. K. Rao, P. Venezia, J. Scupin, C. Lee-Yow and S. LaMar, “Quad-Band Petal Reflector Antenna for Ground Communications,” *2022 IEEE Wireless Antenna and Microwave Symposium (WAMS)*, Rourkela, India, 2022, pp. 1-4.
- [12] R. C. Gupta, K. K. Sood and R. Jyoti, “Compact and High Performance Stepped Truncated-Circular Waveguide Branching Ortho-Mode Transducer (STCWB-OMT),” *Progress in Electromagnetics Research Letters*, vol. 25, pp. 135-141, January 2011.
- [13] CHAMP3D User’s Manual, TICRA, version 22.0, 2022, TICRA, Denmark.
- [14] TICRA TOOL User’s Manual, TICRA, version 22.0, 2022, TICRA, Denmark.
- [15] MATLAB Help Manual, version R2022a, Mathworks Inc, Massachusetts, USA, 2022.